

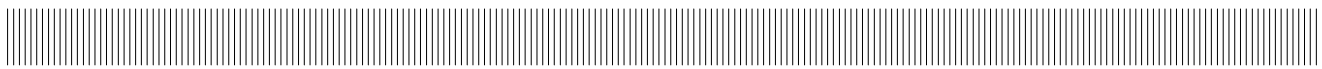

EQUIPAGGIAMENTI
TECNICI
LAVAGGIO

LANCIA SCHIUMA LS12 CON
ASPIRAZIONE ESTERNA
LS12 FOAM LANCES W/EXTERNAL
SUCTION + INJECTOR
LANCE A MOUSSE LS12-ASPIRATION DÉTÉRGENT
EXTERIEURE AVEC INJECTEUR

(I)	26/05/09
(GB)	4
(F)	
	10.9128.00



USO SU IDROPULITRICE DELLA LANCIA SCHIUMA LS12 CON ASPIRAZIONE ESTERNA + INIETTORE
LS12 FOAM LANCE W/EXTERNAL SUCTION + INJECTOR – USE ON HIGH PRESSURE CLEANER
LANCE A MOUSSE LS12 AVEC ASPIRATION DÉTÉRGENT EXTERIEURE + INJECTEUR – MONTAGE SUR UN NETTOYEUR

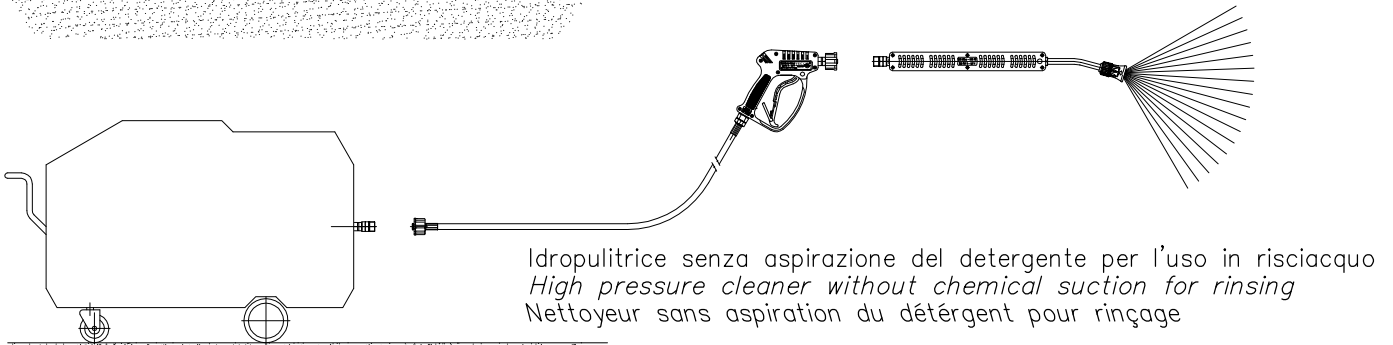

USO SU IMPIANTI FISSI DELLA LANCIA SCHIUMA LS12 CON ASPIRAZIONE ESTERNA + INIETTORE
LS12 FOAM LANCE W/EXTERNAL SUCTION + INJECTOR – USE ON STATIONARY PLANTS
LANCE A MOUSSE LS12 AVEC ASPIRATION DÉTÉRGENT EXTERIEURE + INJECTEUR – MONTAGE SUR INSTALLATIONS FIXES

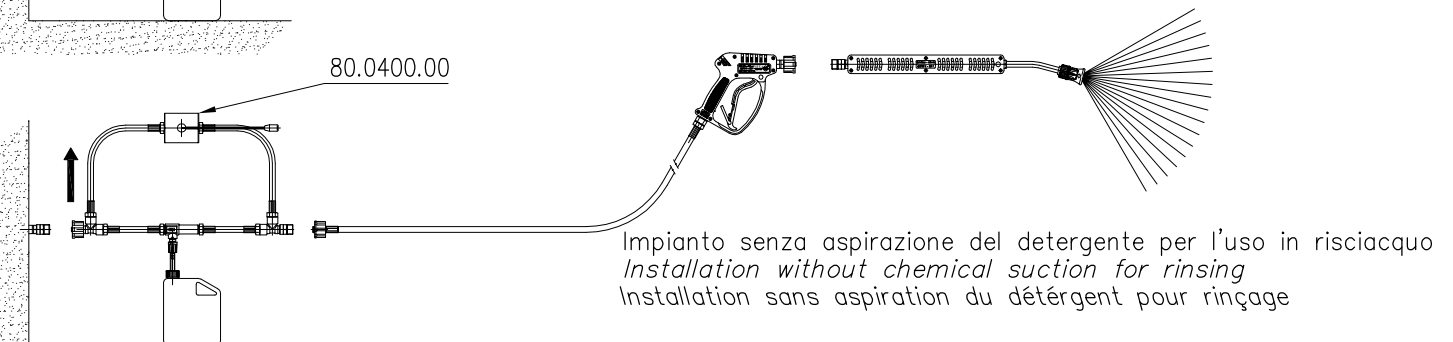
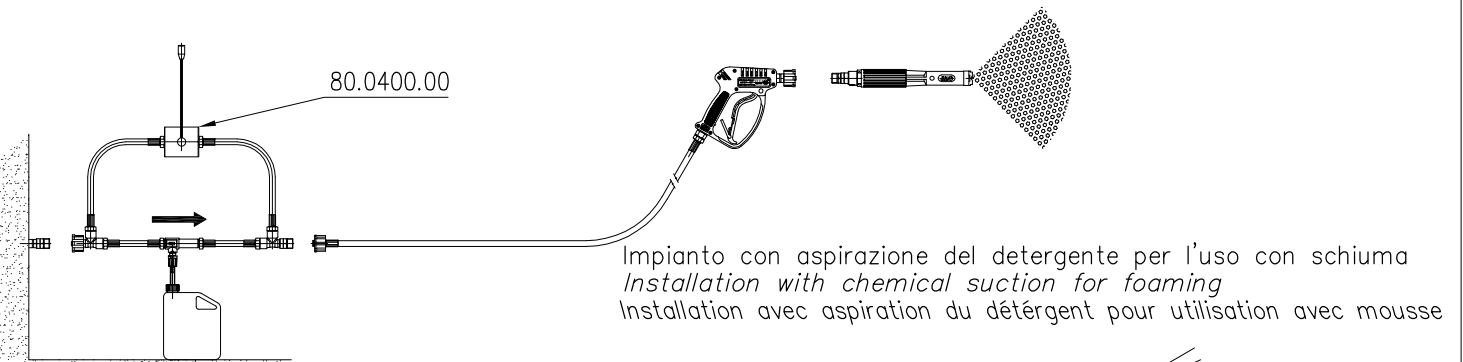

	EQUIPAGGIAMENTI TECNICI LAVAGGIO	Lancia schiuma - Aspirazione detergente con eiettore esterno Foamer - Suction through external injector LS 12		<div style="border: 2px solid black; padding: 2px; display: inline-block;">3</div>
				



SPECIFICHE TECNICHE
SPECIFICATIONS

- PRESSIONE NOMINALE RATED PRESSURE	200 bar - 20 MPa (2900 psi)
- PRESSIONE CONSENTITA PERMISSIBLE PRESSURE	220 bar - 22 MPa (3200 psi)
- PORTATA MASSIMA MAX FLOW RATE	VEDI DIAGRAMMA SEE CHART BELOW
- TEMPERATURA MASSIMA MAX WORKING TEMPERATURE	60° C (140 °F)

MISURE D'INGOMBRO
OVERALL DIMENSIONS

25.1845.18	25.1851.68 + 21.0600.12
25.1845.21	25.1851.71 + 21.0600.14
25.1845.25	25.1851.75 + 21.0600.18

CODICE CODE	UGELLO - NOZZLE mm. [inch.]	A
25.1851.68	1.8 [0.07"]	NERO BLACK
25.1851.71	2.1 [0.083"]	ROSSO RED
25.1851.75	2.5 [0.098"]	BLU BLUE

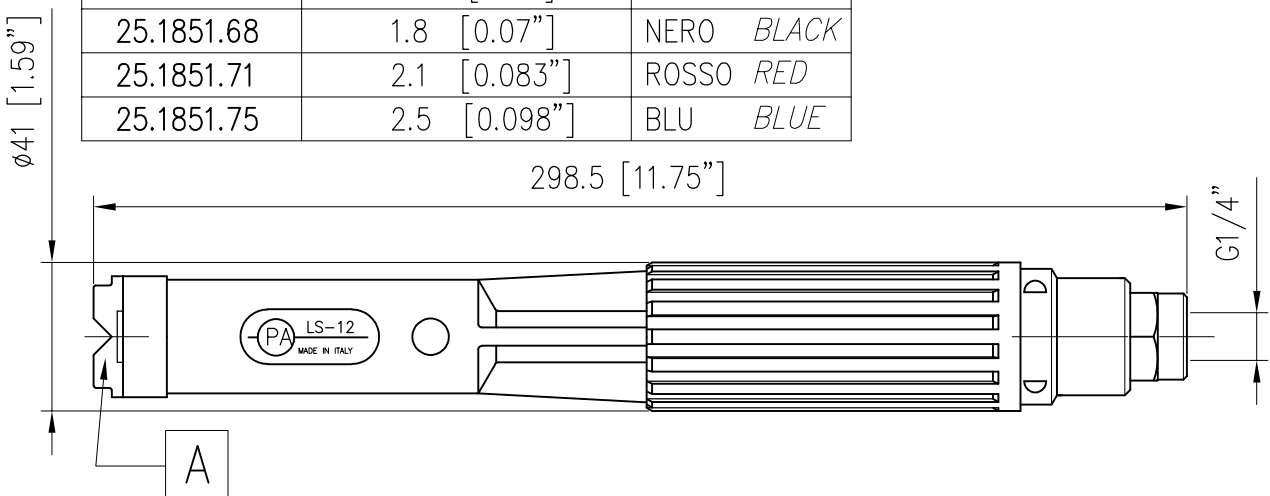

CODICE CODE	UGELLO - NOZZLE mm. [inch.]	B
21.0600.12	1.2 [0.047"]	NERO BLACK
21.0600.14	1.4 [0.055"]	ROSSO RED
21.0600.18	1.8 [0.07"]	BLU BLUE

SCHIUMA FOAM

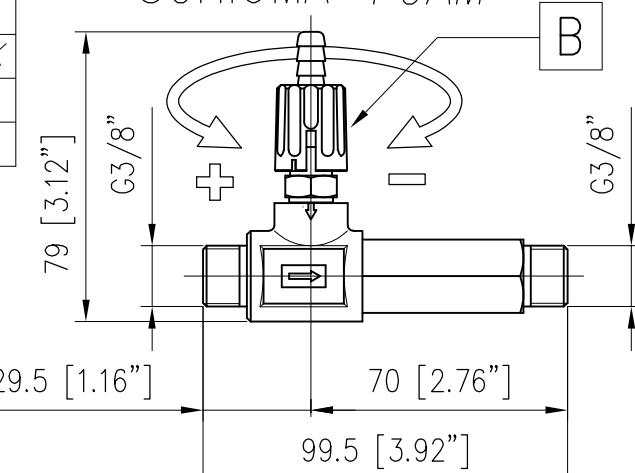
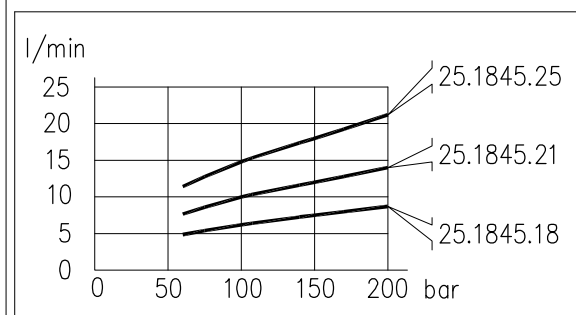
21.0600.12 Eiettore regol. G3/8MM 1,2mm prolun.nero
 21.0600.14 Eiett.reg. G3/8MM 1,4mm prolung.rosso
 21.0600.18 Eiettore regol. G3/8MM 1,8mm prol.blù
 21.0600.21 Eiettore regol. G3/8MM 2,1mm prol.blù
 25.1845.18 LS12asp.e
 25.1845.21 LS12asp.e

25.1845.25 LS12asp.e Lan.schiu.2.5mm+eiett.est.1,8-blù
 25.1851.18 LS12 asp.e-lan.schiu.1,8mm nera
 25.1851.21 LS12 asp.e-lan.schiu.2,1mm rossa
 25.1851.68 LS12 asp.e-lan.schiu.1,8mm nera v.2
 25.1851.71 LS12 asp.e-lan.schiu.2,1mm rossa v.2
 25.1851.75 LS12 asp.e-lan.schiu.2,5mm blù

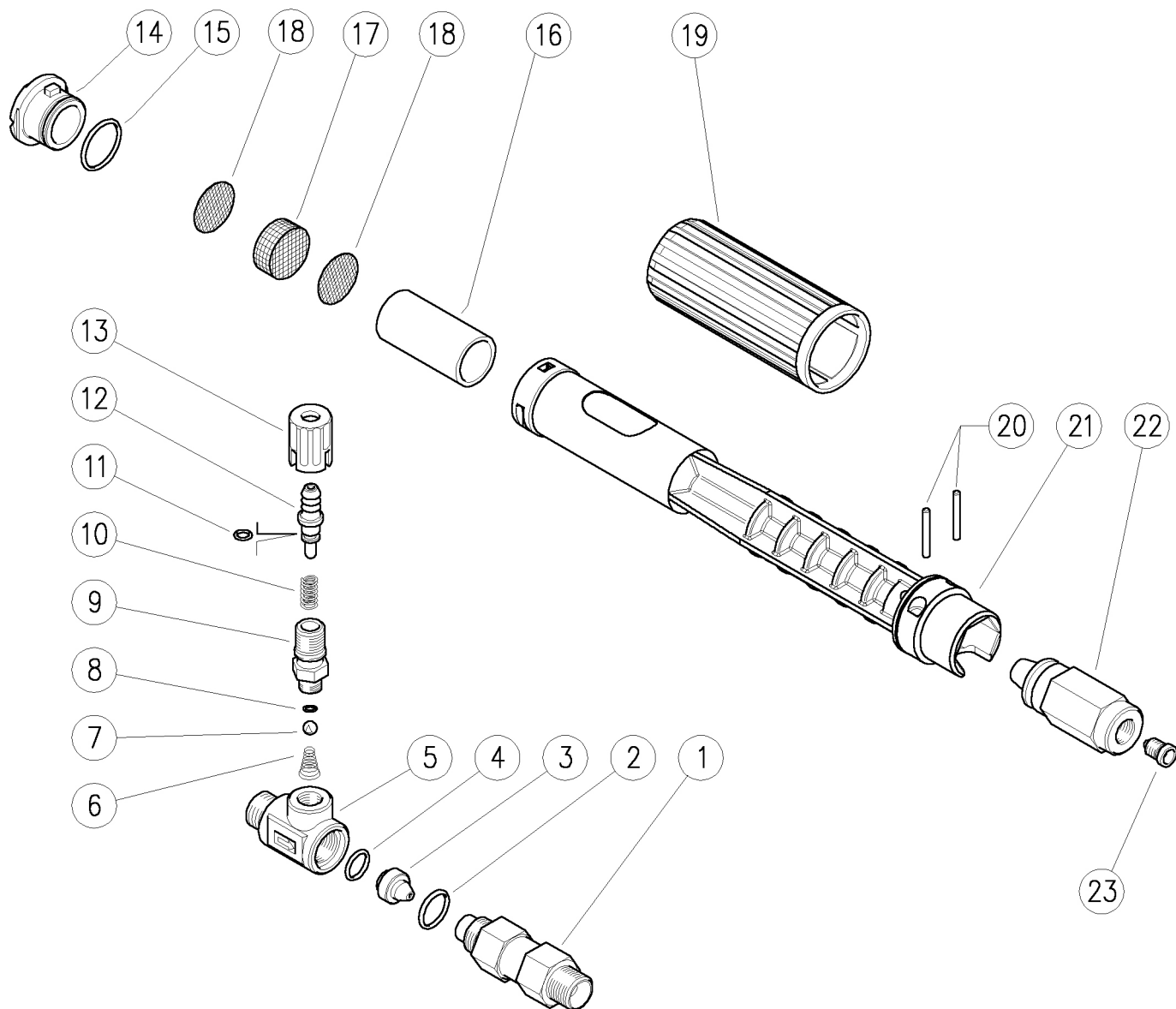

Pos.	Codice	Descrizione	Q.tà	K1	K2	K3	K4		Pos.	Codice	Descrizione	Q.tà	K1	K2	K3	K4	
1	21.0602.31	Raccordo conico G3/8 MM	1					3	13	21.0178.84	Calotta G1/4 blu (4,3)	1					10
2	10.3179.10	An.OR 2,62x13,94 mm Vi 70	1					10	14	25.1802.85	Ugello anteriore plast.nero (1,5)	1					5
3	21.0507.51	Ugello eiett. D.15 - 1,2 mm inox (1)	1					5	14	25.1814.84	Ugello anteriore rosso (2)	1					5
3	21.0508.51	Ugello eiett. D.15 - 1,4 mm inox (2)	1					5	14	25.1814.85	Ugello anteriore rosso v.2 (2,6)	1					5
3	21.0504.51	Ugello eiett. D.15 - 1,8 mm inox (3)	1					5	14	25.1827.85	Ugello ant. LS10 plastica blu v.2 (3,7)	1					5
3	21.0505.51	Ugello eiett. D.15 - 2,1 mm inox (4) **	1					5	15	10.3072.10	An.OR 1,78x20,35 mm Vi 70	1					10
3	21.0506.51	Ugello eiett. D.15 - 2,3 mm inox **	1					5	16	25.1831.85	Anello distanziale LS12	1					5
4	10.3174.10	An.OR 2,62x9,93 mm Vi 70	1					10	17	25.1808.51	Filtro pressato 25x10mm inox	1					10
5	21.0601.35	Corpo eiett. G3/8 MF ott.	1					3	18	29.0802.53	An. Diaframma 25x0,5 mm inox	2					10
6	21.0160.51	Molla conica inox eiett.	1					10	19	25.1805.84	Manopola LS12	1					5
7	14.7420.01	Sfera 7/32" inox Aisi 316	1					10	19	25.1805.85	Manopola LS12 v.2 (5,6,7)	1					5
8	10.3049.00	An.OR 1,78x5,28 mm Vi 70	1					10	20	30.0509.31	Spina cil. 5x24,5 mm ott.	2					10
9	21.0173.31	Raccordo M12x1-G1/4M ott.	1					10	21	25.1801.85	Corpo lancia LS12 v.2	1					5
10	21.0158.51	Molla 0,8x7x15 mm inox	1					10	22	25.1836.31	Corpo eiettore LS12asp.e	1					3
11	10.3043.01	An.OR 1,78x4,48 mm Vi 70	1					10	23	21.0007.51	Ugello M8x1 - 1,5 mm inox	1					10
12	21.0155.99	Portagomma 8 mm ott.+or	1					3	23	21.0002.51	Ugello M8x1 - 1,8 mm inox (1)	1					10
13	21.0171.84	Manopola eiett. G1/4F nera (1)	1					10	23	21.0004.51	Ugello M8x1 - 2,1 mm inox (2)	1					10
13	21.0174.84	Calotta G1/4 rossa (2)	1					10	23	21.0009.51	Ugello M8x1 - 2,5 mm inox (3)	1					10

** Su richiesta

(1) 25.1845.18 (2) 25.1845.21 (3) 25.1845.25 (4) 21.0600.21 (5) 25.1851.68 (6) 25.1851.71 (7) 25.1851.75

21.0600.12 Injector,adjust. 3/8MM Bsp 1,2mm
 21.0600.14 Inject.,adj. 3/8MM Bsp 1,4mm extrn.red
 21.0600.18 Inject.,adj. 3/8MM Bsp 1,8mm extrn.blue
 21.0600.21 Inject.,adj. 3/8MM Bsp 2,1mm extrn.blue
 25.1845.18 LS12asp.e Foamer 1,8mm+ext.inje.1,2-black
 25.1845.21 LS12asp.e Foamer 2.1mm+ext.inject.1,4-red

25.1845.25 LS12asp.e Foamer 2.5mm+ext.inject.1,8-blue
 25.1851.18 LS12 asp.e Foam lance exter.suct. 1,8-black
 25.1851.21 LS12 asp.e Foam lance exter.suct. 2,1mm
 25.1851.68 LS12 asp.e Foam lance exter.suct. 1,8-black
 25.1851.71 LS12 asp.e Foam lance exter.suct. 2,1mm
 25.1851.75 LS12 asp.e Foam lan.exter.suct. 2,5-blue

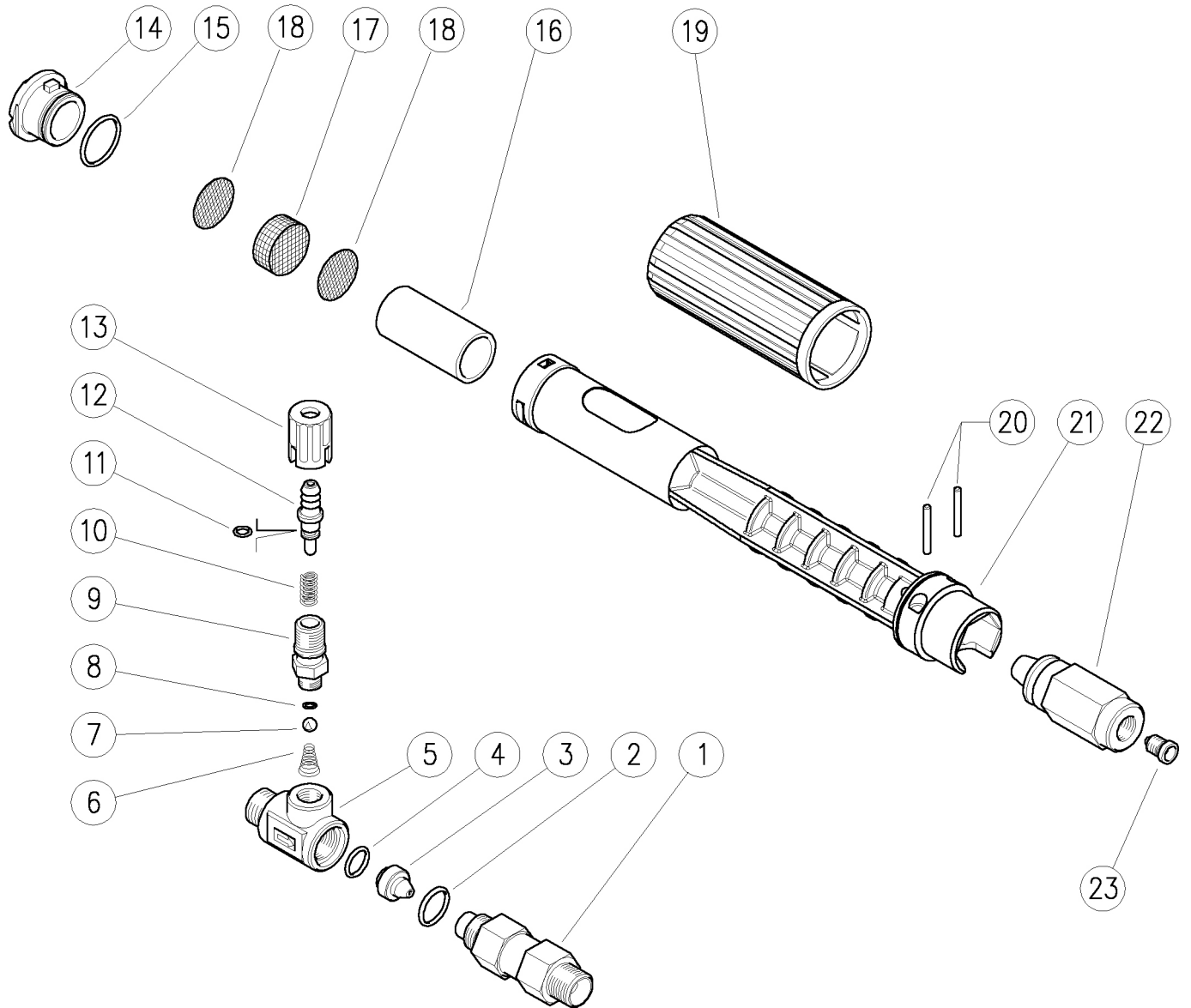

Pos.	P/N	Description	Q.ty	K1	K2	K3	K4		Pos.	P/N	Description	Q.ty	K1	K2	K3	K4	
1	21.0602.31	Tapered coupling, 3/8MM Bsp	1					3	13	21.0178.84	Inject.knob, 1/4F Bsp blue (4,3)	1					10
2	10.3179.10	O-ring, 2,62x13,94 mm Vi 70	1					10	14	25.1802.85	Front nozzle -LS10-12 black v.2 (1,5)	1					5
3	21.0507.51	Inject.nozzle, D.15 - 1,2 mm Sst. (1)	1					5	14	25.1814.84	Front nozzle -LS10-12 red (2)	1					5
3	21.0508.51	Inject.nozzle, D.15 - 1,4 mm Sst. (2)	1					5	14	25.1814.85	Front nozzle -LS10-12 red v.2 (2,6)	1					5
3	21.0504.51	Inject.nozzle, D.15 - 1,8 mm Sst. (3)	1					5	14	25.1827.85	Front Nozzle LS10 plastic blue (3,7)	1					5
3	21.0505.51	Inject.nozzle, D.15 - 2,1 mm Sst. (4) **	1					5	15	10.3072.10	O-ring, 1,78x20,35 mm Vi 70	1					10
3	21.0506.51	Inject.nozzle, D.15 - 2,3 mm Sst. **	1					5	16	25.1831.85	Spacer ring -LS12	1					5
4	10.3174.10	O-ring, 2,62x9,93 mm Vi 70	1					10	17	25.1808.51	Pressed strainer,25x10mm Sst.	1					10
5	21.0601.35	Inject.housing, 3/8MF Bsp brass	1					3	18	29.0802.53	Diaphragm, 25x0,5 mm Sst.	2					10
6	21.0160.51	Tapered spring, Sst. -inject.	1					10	19	25.1805.84	Knob -LS12	1					5
7	14.7420.01	Ball, 7/32" Sst. Aisi 316	1					10	19	25.1805.85	Knob -LS12 v.2 (5,6,7)	1					5
8	10.3049.00	O-ring, 1,78x5,28 mm Vi 70	1					10	20	30.0509.31	Parallel pin, 5x24,5 mm brass	2					10
9	21.0173.31	Coupling, M12x1-1/4M Bsp brass	1					10	21	25.1801.85	Lance housing -LS12 v.2	1					5
10	21.0158.51	Spring, 0,8x7x15 mm Sst.	1					10	22	25.1836.31	Injector housing -LS12asp.e	1					3
11	10.3043.01	O-ring, 1,78x4,48 mm Vi 70	1					10	23	21.0007.51	Nozzle, M8x1 - 1,5 mm Sst.	1					10
12	21.0155.99	Hose barb, d.8 mm brass+o-ring	1					3	23	21.0002.51	Nozzle, M8x1 - 1,8 mm Sst. (1)	1					10
13	21.0171.84	Inject.knob, 1/4F Bsp black (1)	1					10	23	21.0004.51	Nozzle, M8x1 - 2,1 mm Sst. (2)	1					10
13	21.0174.84	Inject.knob, 1/4F Bsp red (2)	1					10	23	21.0009.51	Nozzle, M8x1 - 2,5 mm Sst. (3)	1					10

** On request

(1) 25.1845.18 (2) 25.1845.21 (3) 25.1845.25 (4) 21.0600.21 (5) 25.1851.68 (6) 25.1851.71 (7) 25.1851.75